

Repair Parts Sheet	Revision	Revision Date	Product Code Beginning
Reference nr. L2806	B	09/11	B

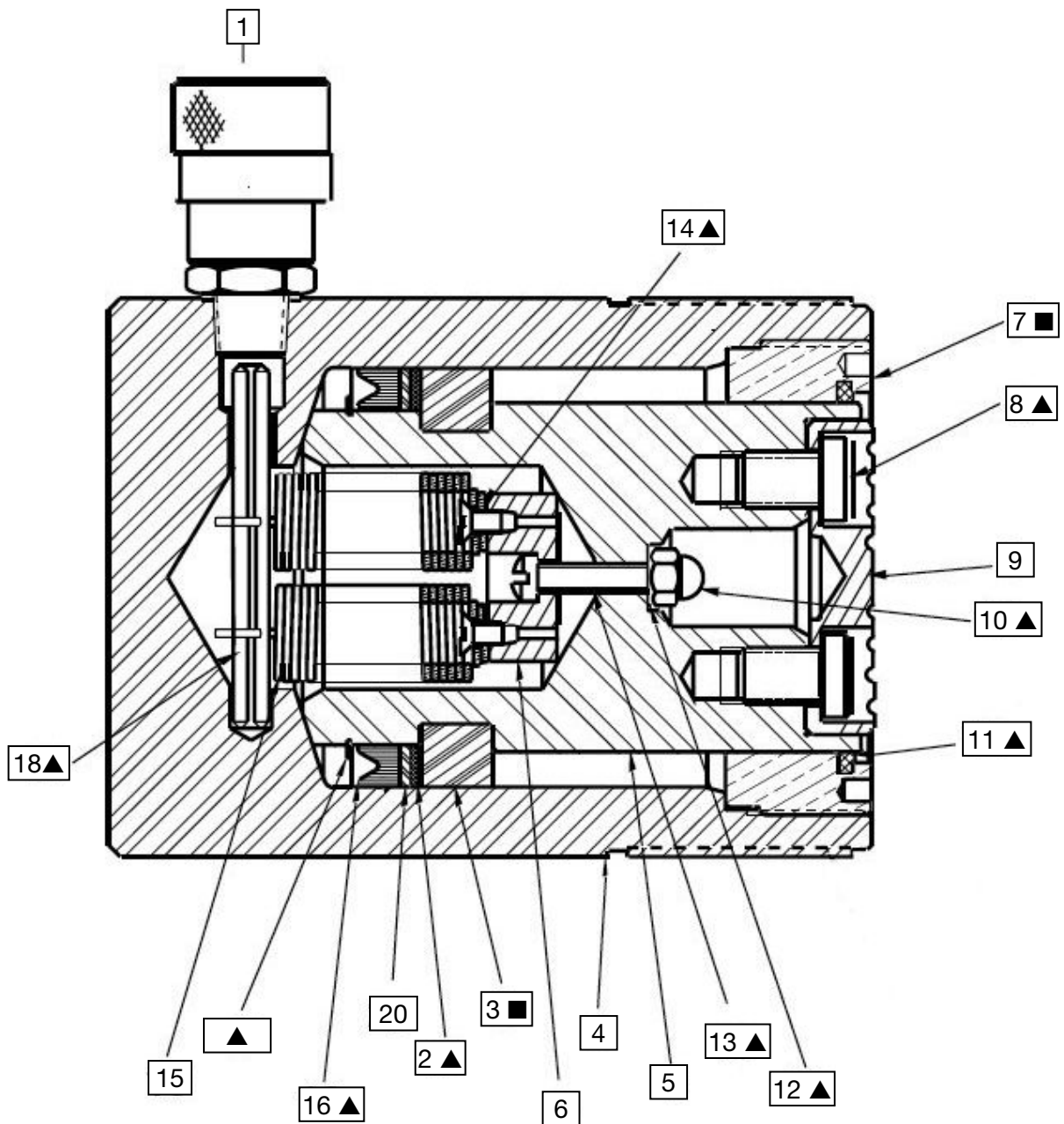

▲ = RC50K50
 ▲+■ = RC50K70

Figure 1

Repair Parts List RC502 & RC504 Figure 1

L 2806

Item. Nr.	Description	Qty.	RC502	RC504
1	Coupler	1	CR400	CR400
2	Washer	1	▲	▲
3	Bearing	1	■	■
4	Cylinder Base	1	Not available, order complete cylinder.	
5	Plunger	1	CB603040	CH170040
6	Spring Anchor (incl. Item 18, 14, 13, 12, 10)	1	DA2285101SR	DA2285101SR
7	Stop Ring	1	■	■
8	Cap Screw	2	▲	▲
9	Saddle (incl. item 8)	1	L345045SR	L345045SR
10	Acorn Nut	1	▲	▲
11	Wiper	1	▲	▲
12	Gasket	1	▲	▲
13	Screw	1	▲	▲
14	Screw	2	▲	▲
15	Spring Assy (includes item 14 & 18)	2	L202110SR	
15	Cylinder spring (set of 2 including items 14 & 18)	1		CB425110SR
16	U Cup	1	▲	▲
17	Retaining Ring	1	▲	▲
18	Spring Pin	1	▲	▲
19	Thread Protector (not shown)	1	▲	▲
20	Washer (Viton cylinders only)	1		
21	Coupler O-ring (not shown)	1	▲	▲
22	Enerpac Decal (not shown)	3	▲	▲
23	Warning Decal (not shown)	1	▲	▲
24	Dust Cap (not shown)	1	▲	▲
25	Handle Assembly (not shown)	1		CK571070

▲ = Indicates items included in and only available as part of repair kit RC50K50

■ = Indicates items included in and only available as part of repair kit RC50K70. RC50K70 includes 1x RC50K50

RC506KV (Viton kit) contains items nr. 2, 11, 12, 16, 17, 18, 20



Item nr.	Torque / Remarks
1	34 - 81 Nm 25 - 60 ft lbs
1	Use Teflon tape or Loctite 545
2	Washer to be placed with sharp edge towards U Cup
7	Secure with Loctite 222
10	11 - 14 Nm 8 - 10 ft lbs
13	Firmly tighten screw to assure contact with plunger.

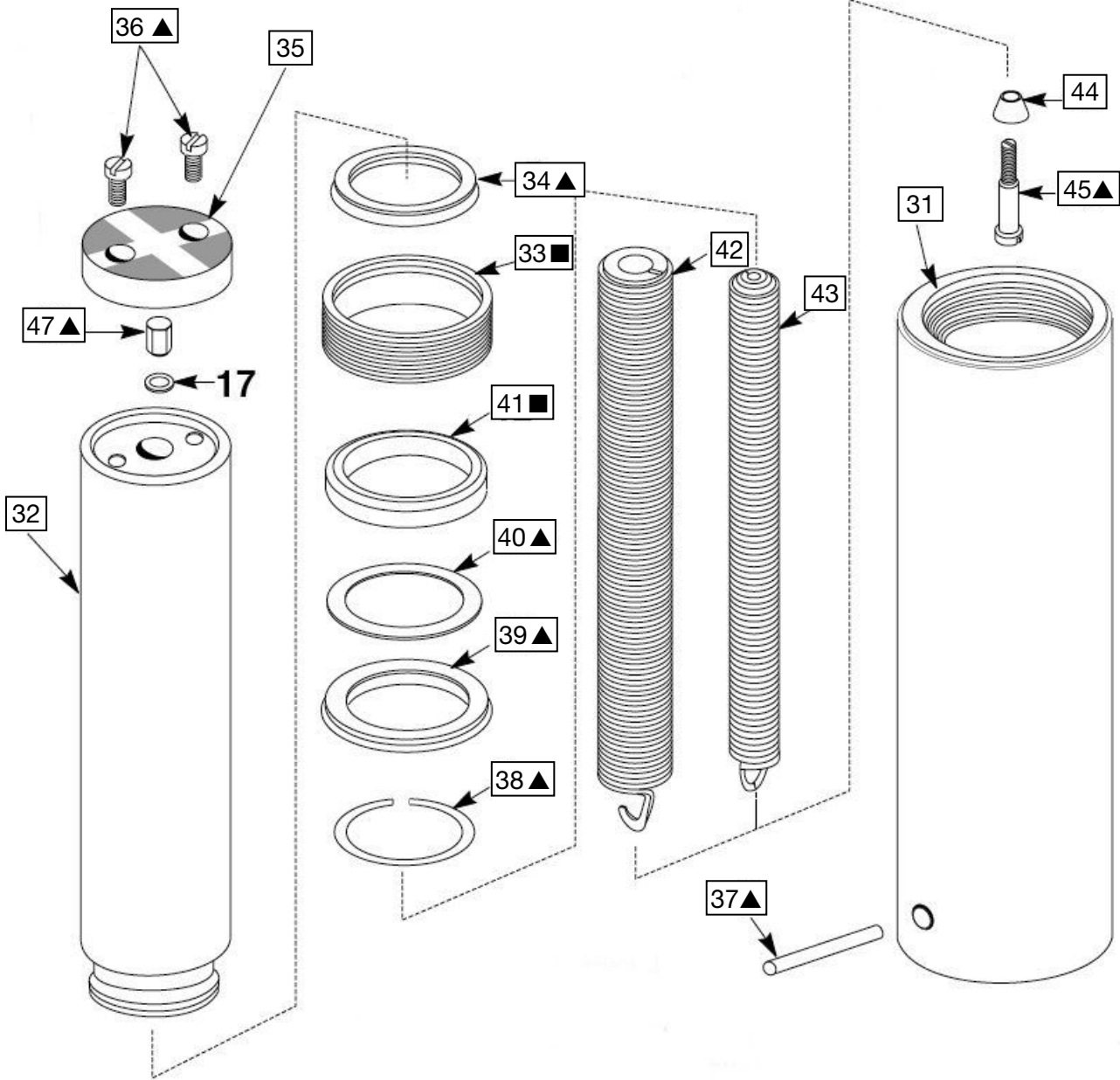

▲ = RC50K50
 ▲+■ = RC50K70

Figure 2

Repair Parts List RC506 & RC5013 Figure 2				L 2806
Item. Nr.	Description.	Qty.	RC506	RC5013
30	Coupler (not shown)	1	CR400	CR400
31	Cylinder Base	1	Not available, order complete cylinder.	
32	Plunger	1	L347040	L357040
33	Stop Ring	1	■	■
34	Wiper	1	▲	▲
35	Saddle (incl. item 36)	1	L345045SR	L345045SR
36	Screw	2	▲	▲
37	Spring Pin	1	▲	▲
38	Retaining Ring	1	▲	▲
39	U Cup	1	▲	▲
40	Washer	1	▲	▲
41	Bearing (set of 2)	1	■	■
42	Spring (incl. item 37, 42, 43, 44, 45, 46)	1		CB455110SR
42	Spring (incl. item 37, 43, 44, 45)	1	CB349110SR	-
43	Spring	1		see item 42
44	Bushing	1		
45	Adjusting Screw	1	▲	▲
46	Gasket	1	▲	▲
47	Acorn Nut	1	▲	▲
48	Handle Assy (not shown)	1	CK571070	CL1052950
49	Coupler O-ring (not shown)	1	▲	▲
50	Enerpac Decal (not shown)	3	▲	▲
51	Warning Decal (not shown)	1	▲	▲
52	Dust Cap (not shown)	1	▲	▲
53	Thread Protector (not shown)	1	▲	▲

▲ = Indicates items included in and only available as part of repair kit RC50K50

■ = Indicates items included in and only available as part of repair kit RC50K70. RC50K70 includes 1x RC50K50



Item nr.	Torque / Remarks
30	34 - 81 Nm 25 - 60 ft lbs
30	Use Teflon tape or Loctite 545
33	Secure with Loctite 222
40	Washer to be placed with sharp edge towards U Cup
45	Firmly tighten screw to assure contact with plunger.
47	11 - 14 Nm 8 - 10 ft lbs



To maintain your warranty:

- Use only Enerpac Oil
- Have your products inspected and repaired by an Enerpac Authorized Service Center

ENERPAC 

Visit www.enerpac.com for the location of the Enerpac Authorized Service Center nearest you.