

CORDLESS HYDRAULIC TORQUE PUMPS

THE NEXT GENERATION OF CORDLESS PERFORMANCE AND EFFICIENCY



Works with



XC2-SERIES

ENERPAC 

▼ XC2502BE



The Next Generation of Cordless Performance and Efficiency



Works with



Use the Enerpac Connect Mobile App for the latest essential tool information. Scanning the QR code on the pump gives instant access to product specifications, manuals, videos, job specific usage data, and wireless firmware updates.

Works with



- Cordless convenience eliminates extension cords, noise and emission producing generators
- Ideal for bolting applications requiring portability and convenience
- 6 metres detachable pendant control
- 100 mm glycerine-filled gauge for easy viewing
- Adjustable pressure relief valve can be locked when desired pressure is set
- High-performance brushless motor drives flow rate comparable to 0,37 kW electric pumps for increased productivity and provides twice the life of brushed motors
- Bladder reservoir reduces contamination and allows pump use in any position
- Accessory shoulder strap SSTRP55 attaches to integrated steel rings for enhanced portability
- Compatible with the Enerpac Connect App, which gives access to the latest tool & job information.



Pendant Controls

The heavy-duty pendants operate any XC2-Series pumps. Easy to connect or disconnect when not required, the pendants feature large buttons, an over molded grip, lanyard loop and hanger magnet. Multiple seals within pendant provide IP64 environmental protection.

Description	Model Nr.
Pendant, 3 m cord	CC131
Pendant, 6 m cord	CC132
Extension Cord, 3 m	CC010



54 Volt Lithium-Ion Battery

The 4 Ah EBH544 battery with high-capacity cells provides extended runtime for higher cycle and larger tool and cylinder applications.



54 Volt Fast Battery Charger

The fast charger minimizes downtime with a 1½ hour charge cycle. Charger provides charge status, over-temperature and damaged battery indication.

54 Volt Fast Charger	Model Nr.
115 Volt North America	EC1F541B
230 Volt Europe	EC1F542E
230 Volt Australia	EC1F542A



Torque Wrenches

The following torque wrenches are ideal for use with the XC2-Series Cordless Torque Pumps:

S	W	RSL	DSX	HMT
S1500X	W2000X	RSL1500	DSX1500	HMT1500
S3000X	W4000X	RSL3000	DSX3000	HMT3500
		RSL5000		HMT7500

Larger torque wrenches may be used with the pump.

Cordless Torque Pumps



XC2-Series Torque Pumps

The XC2-Series Cordless Torque Pump is ideal for applications where a power supply is not available or extension cords present safety or mobility issues.

Whether in the field or facility, the XC2 combination of portability, productive fastening speed and battery run time will increase the efficiency of any job.

If working in confined spaces where any cord is a challenge, the pendant control is easily detached and the pump can be operated by the trigger.



Torque Wrench Model	Application	Nut A/F	Stud	Torque (Nm)	Passes	Fasteners Torqued ²⁾
W2000X	Hard Joint	60 mm	38 mm	1356	Single	84
W2000X	Flange 1500# ¹⁾	2 inch	1 1/4 inch	1320	3 + Ringer	32 ³⁾

¹⁾ Flange 1500#, 4 inch, 8 x 1 1/4 inch

²⁾ Actual number of fasteners per charge will vary depending on condition of tools and materials.

³⁾ 32 = 1 flange.

XC2 Series



Reservoir Capacity:
2,0 - 4,0 litres

Flow at Rated Pressure:
0,33 l/min

Motor & Battery Size:
0,70 kW, 54 V / 4 Ah

Maximum Operating Pressure:
700 bar

- ① Outlet "Advance" Port 1/4"-18 NPTF
- ② Inlet "Retract" Port 1/4"-18 NPTF
- ③ Pendant connection port
- ④ User Adjustable Relief Valve
- ⑤ Pressure Gauge (bar, psi, MPa)
- ⑥ Shoulder Strap Connection Points
- ⑦ Trigger Lock
- ⑧ Trigger
- ⑨ Oil Fill (must use funnel)

Pendant Control



Press to advance, release to retract

Motor Stop, Auto Dump



Torque Wrench Hoses

Use Enerpac THQ-Series torque wrench hoses with torque wrenches and torque pumps.

2 m long, 2 hoses	THQ702T
6 m long, 2 hoses	THQ706T
12 m long, 2 hoses	THQ712T

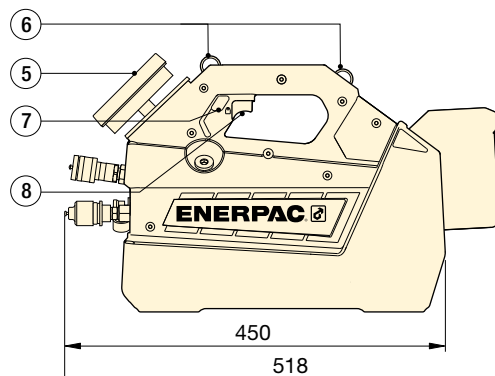
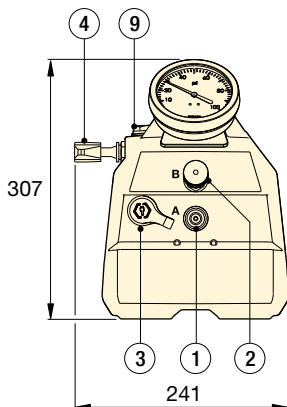

OIL FLOW vs. PRESSURE

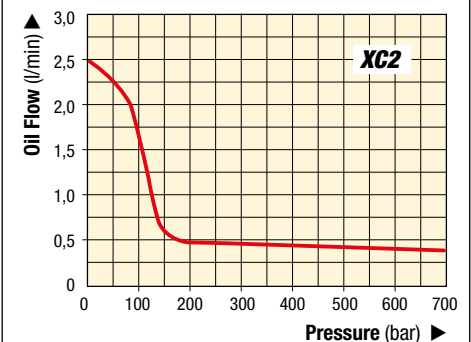

▼ SELECTION CHART

Torque Pump for use with	Useable Oil Capacity (litres)	Model Number	Output Flow Rate (l/min)		Valve Function	Pendant in kit	Batteries in kit	Charger in kit	Weight (kg)
			No Load	700 bar					
All Series torque wrenches	2,0	XC2502B	2,60	0,33	Solenoid 4-way, 2-pos.	CC132	-	-	15,2
	4,0	XC2504B							16,8
	2,0	XC2502BE ⁴⁾							15,2
	4,0	XC2504BE ⁴⁾							16,8

⁴⁾ Pumps available with 115 V North American plugset charger. Substitute "E" suffix with "B" in model number. Example: **XC2504BB**.

Pumps available with 230 V Australian plugset charger. Substitute "E" suffix with "A" in model number. Example: **XC2504BA**.

⁵⁾ Weight includes pump with oil and battery. Weight 1,6 kg per battery.



BOLTING SOLUTIONS

THE RIGHT TOOL MAKES ALL THE DIFFERENCE

Energac bolting tools are put to work under the most intense and demanding conditions. That's why we never compromise. So you can rely on quality and precision every time for your controlled tightening and joint integrity applications.

As a global leader in high-pressure hydraulic tools, controlled force products and solutions for precision positioning of heavy loads, Energac products have moved and maintained some of the largest structures on earth. They are the industry standard in aerospace, infrastructure, manufacturing, mining, oil & gas, power generation and much more.

Elite Tools. For Elite Professionals.

Controlled Tightening and Loosening



S-, W-, RSL-, DSX and HMT-Series Hydraulic Torque Wrenches



STTL- Safe T™ Torque Lock



STTC- Safe T™ Torque Checker



Manual & Pneumatic Multipliers



Cordless Torque Pumps



Electric Torque Pumps



Pneumatic Torque Pumps

Tensioning Tools



Power Generation Bolt Tensioners



HydraMax, General Purpose and Aquajack® Subsea Tensioners



Electric Tensioning Pumps



Pneumatic Tensioning Pumps



High-Pressure Hand Pumps

Joint Assembly & Joint Separation



Nut Splitters



Flange Alignment Tools



Flange Face Tools



Flange Spreaders



Flange Puller Sets



Valve Change-Out Tool Sets