

# CORDLESS HYDRAULIC PUMPS

THE NEXT GENERATION OF CORDLESS PERFORMANCE AND EFFICIENCY



Works with



**XC2-SERIES**

**ENERPAC** 

▼ From left to right: XC2402ME, XC2302SE



- **Cordless convenience eliminates extension cords, noise and emission producing generators**
- **High-Performance brushless motor drives high-flow rates for increased productivity and provides twice the life of brushed motors**
- **Bladder reservoir reduces contamination and allows pump use in any position**
- **Pump models with 4 litres oil capacity enable use with larger and multiple cylinders**
- **Accessory shoulder strap SSTRP55 attaches to integrated steel rings for enhanced portability**
- **Compatible with the Enerpac Connect App, which gives access to the latest tool & job information**
- **Torque pump models available, see Bolting Tools section.**

▼ *Variable Speed Trigger: Featured on manual valve models. Enables greater precision of tool or cylinder travel.*



**4 litres reservoir**  
Pump models with 4 litres oil capacity enable use with larger and multiple cylinders.



4 litres XC2 pump can be used with:	
One	<b>RC10010</b> 100 ton cylinder
Two	<b>RC756</b> 75 ton cylinders
Three	<b>RC506</b> 50 ton cylinders
Four	<b>RC504</b> 50 ton cylinders

## The Next Generation of Cordless Performance and Efficiency



Works with



Use the Enerpac Connect Mobile App for the latest essential tool information. Scanning the QR code on the pump gives instant access to product specifications, manuals, videos, job specific usage data, and wireless firmware updates.



### Pendant Controls

Heavy-duty pendants operate any Enerpac XC2-Series pump. Easy to connect or disconnect when not required, the pendants feature large buttons, an over molded grip, lanyard loop and hanger magnet. Multiple seals within the pendant provide IP64 environmental protection.

Description	Model Nr.
Pendant, 3 m cord	<b>CC131</b>
Pendant, 6 m cord	<b>CC132</b>
Extension Cord, 3 m	<b>CC010</b>



### 54 Volt Lithium-Ion Battery

The 4 Ah **EBH544** battery with high-capacity cells provides extended runtime for higher cycle and larger tool and cylinder applications.



### 54 Volt Fast Battery Charger

The fast charger minimizes downtime with a 1½ hour charge cycle. Charger provides charge status, over-temperature and damaged battery indication.

54 Volt Fast Charger	Model Nr.
115 Volt North America	<b>EC1F541B</b>
230 Volt Europe	<b>EC1F542E</b>
230 Volt Australia	<b>EC1F542A</b>

# Cordless Hydraulic Pumps



## XC2-Series Cordless Pumps

The XC2-Series pumps take speed, battery run time and oil capacity to new levels greatly expanding the usage opportunities. Capable of larger tool and cylinder applications, cordless convenience can be extended further in the field or facility.

Manual valve models feature a variable speed trigger for greater control of tool or cylinder advance and the Enerpac 54 Volt battery system enables significant work completion on a single battery charge.

The high-performance brushless motor provides the speed of a 0,37 kW electric pump enabling corded productivity with cordless convenience.



Tool / Cylinder	Application	Per Charge
NC5060 Nut Splitter	50 mm, A194 Grade 2H Heavy Hex Nut	57x
SP35 Punch	20,6 mm hole, 6,5 mm mild steel	317x
RCS302 Cylinder	220 kN, 38 mm extension	43x
RAR506 Cylinder	400 kN, 76 mm extension	10½x
RAR1006 Cylinder	800 kN, 76 mm extension	4½x

## XC2 Series



Reservoir Capacity:  
**2,0 - 4,0 litres**

Flow at Rated Pressure:  
**0,33 l/min**

Motor & Battery Size:  
**0,70 kW, 54 V / 4 Ah**

Maximum Operating Pressure:  
**700 bar**

- ① Outlet "Advance" Port 3/8"-18 NPTF
- ② Inlet "Retract" Port 3/8"-18 NPTF \*
- ③ Pendant connection port
- ④ User Adjustable Relief Valve Access
- ⑤ Directional Control Valve \*\*
- ⑥ Shoulder Strap Connection Points
- ⑦ Trigger Lock \*\*
- ⑧ Variable speed trigger \*\*
- ⑨ Oil Fill (must use funnel)

\* On Double-Acting models  
\*\* On Manual Valve models

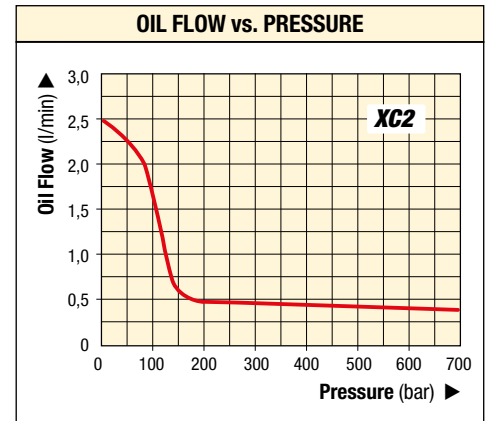
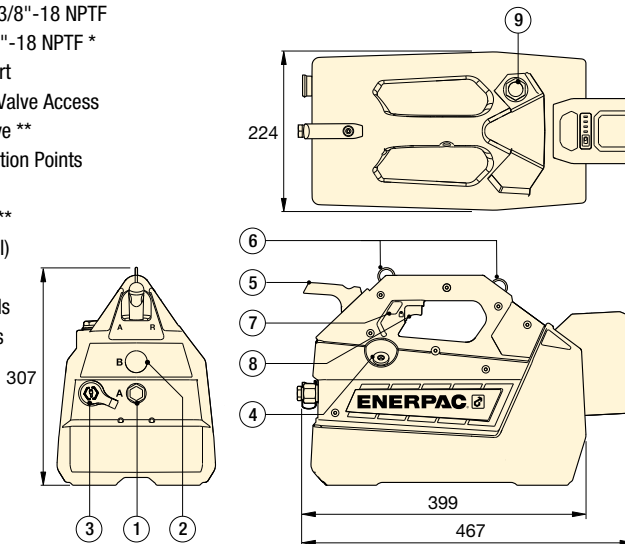

### SELECTION CHART

Pump Type (Used with cylinder)	Useable Oil Capacity (litres)	Model Number <sup>1)</sup>	Output Flow Rate (l/min)		Valve Function	Pendant in kit	Batteries in kit	Charger in kit	Weight <sup>2)</sup> (kg)
			No Load	700 bar					
Single-Acting	2,0	<b>XC2202M</b>	2,60	0,33	Manual 3-way, 2-position	-	-	-	11,9
	4,0	<b>XC2204M</b>							13,5
	2,0	<b>XC2202ME</b>							11,9
	4,0	<b>XC2204ME</b>							13,5
Single-Acting	2,0	<b>XC2302S</b>	2,60	0,33	Solenoid 3-way, 2-position	CC131	-	-	12,8
	4,0	<b>XC2304S</b>							14,4
	2,0	<b>XC2302SE</b>							12,8
	4,0	<b>XC2304SE</b>							14,4
Double-Acting	2,0	<b>XC2402M</b>	2,60	0,33	Manual 4-way, 3-position	-	-	-	12,8
	4,0	<b>XC2404M</b>							14,4
	2,0	<b>XC2402ME</b>							12,8
	4,0	<b>XC2404ME</b>							14,4

<sup>1)</sup> Pumps available with 115 V North American plugset charger. Substitute "E" suffix with "B" in model number. Example: **XC2204MB**.

Pumps available with 230 V Australian plugset charger. Substitute "E" suffix with "A" in model number. Example: **XC2304SA**.

<sup>2)</sup> Weight includes pump with oil and battery. Battery weight 1,6 kg.



# TOOL SOLUTIONS

## THE RIGHT TOOL MAKES ALL THE DIFFERENCE

Enerpac offers an extensive range of tools to ensure that even your most demanding applications can be undertaken with the highest degree of safety and accuracy. Whatever your requirement — lifting, pressing, cutting, punching, spreading or bending; you can be sure that Enerpac has the correct tool to do your job safely and efficiently.

**Elite tools. For Elite Professionals.**



Cylinders & Lifting Products



Cylinder-Pump Sets



Cordless Hydraulic Pumps



Pullers



Lifting Wedges



Machine Lifts



Punches



Spreaders



Maintenance Sets



Pipe Benders



Cutters



Nut Cutters