

▼ RT3311 Telescopic Cylinder (shown with plunger extended and retracted)



- Nitrocarburized surface treatment inside and out provides corrosion protection
- 3% side-load of full capacity
- Double or triple wear bearings support lifting stages
- Tilting saddles with 5 degrees of maximum tilt standard on all models
- Design Safety factor complies with ASME B30.1 & EN1494
- Certified lifting eyes for safe handling and positioning
- CR400 coupler for compatibility with standard product
- Steel cylinder base for maximum strength.



◀ *The longer stroke length of telescopic cylinders will save you time and simplify projects by moving a load a greater distance and eliminating the use of temporary cribbing.*

## Moving a load a greater distance



### RT-Series, Multi-Stage Cylinders

Enerpac compact, multi-stage telescopic cylinders are available with two or three pistons, and can lift loads up to 600 mm in a single movement.

Nitrocarburized surface treatment inside and out provides unparalleled sideload resistance and corrosion protection for safe use in the harshest conditions. The longer stroke length of telescopic cylinders will save you time and simplify projects by moving a load a greater distance and eliminating the use of temporary cribbing.

### Multi-Stage Cylinders

**1st Stage:** maximum load capacity at lowest maximum stroke

**2nd Stage:** extended stroke but at lower maximum capacity than the 1st stage

**Final Stage:** maximum stroke extension but lowest maximum capacity.

**WARNING:** If several telescopic cylinders need to be controlled simultaneously Enerpac recommend the use of EVO or EVOB-Series Synchronous Lifting Pumps. Enerpac advise not to use SFP-Series Split-Flow pumps to operate several telescopic cylinders at a time due to the volume difference on the different stages.



### Tilt Saddles

All RT-Series cylinders include integral tilt saddles with maximum tilt angles up to 5 degree.

Cylinder Capacity at Maximum Stroke ton (kN)	Maximum Stroke (mm)	Model Number	Collapsed Height	
			A (mm)	B (mm)
14,0 (137)	270	RT1510	283	553
17,0 (166)	435	RT1817	345	780
20,2 (198)	300	RT2111	317	617
	500	RT2119	395	895
31,5 (309)	300	RT3311	352	652
	600	RT3323	476	1076

# Multi-Stage Telescopic Cylinders, Single-Acting, Load Return

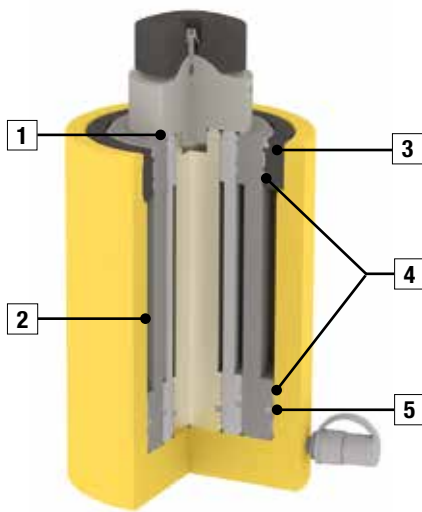

- 1 **Wiper Ring** on each stage to minimize contamination.
- 2 **Nitrocarburized Coating** for maximum corrosion protection and surface hardness. Exterior in nitrided and Enerpac yellow epoxy.
- 3 **Stop Ring** full load capable to prevent plunger overstroke.
- 4 **Wear Bearings**. Double or triple wear bearings for maximum sideload capability and wear resistance.
- 5 **Seals** for maximum compliance and high wear resistance.

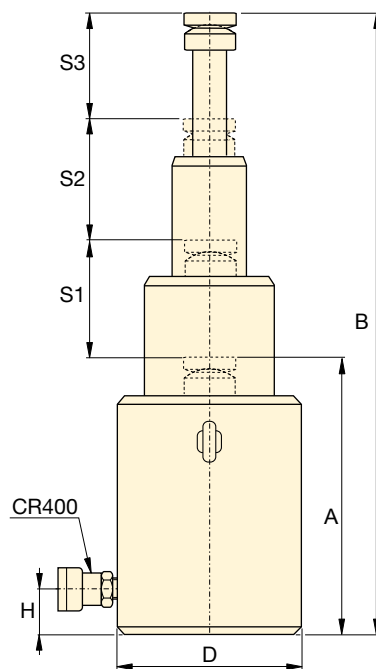
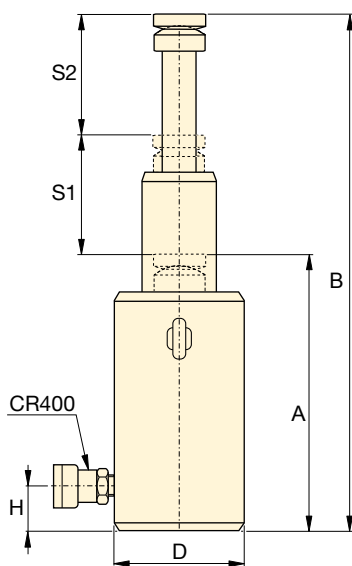
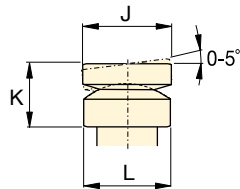

## RT Series



Capacity:  
**14 - 31,5 ton**

Stroke:  
**270 - 600 mm**

Maximum Operating Pressure:  
**700 bar**



### Assisted-return Pumps with Venturi Valve Technology

To improve productivity and plunger retraction, Enerpac offers valve configurations designed to

accelerate your cylinder retraction speeds, ZU4 and ZE-Series pumps feature **Venturi Valve Technology** to facilitate the faster return of single-acting load and spring-return cylinders. See [enerpac.com](http://enerpac.com) for details.

Page: **123**



### Hoses

Enerpac offers a complete line of high quality hydraulic hoses. To ensure the integrity of your system, specify only Enerpac

hydraulic hoses.

Page: **128**

Oil Capacity (cm <sup>3</sup> )	1st Stage		2nd Stage		3rd Stage		Outside Diameter D (mm)	Bottom to Advance Port H (mm)	Saddle Diameter J (mm)	Saddle Protrusion from Plgr. K (mm)	Saddle Support Diameter L (mm)	Model Number	
	Capacity ton (kN)	Stroke S1 (mm)	Capacity ton (kN)	Stroke S2 (mm)	Capacity ton (kN)	Stroke S3 (mm)							
944	<b>36</b> (352)	135	<b>14</b> (137)	135	–	–	110	20	60	49	60	15,1	<b>RT1510</b>
3092	<b>95</b> (929)	145	<b>41</b> (397)	145	<b>17,0</b> (166)	145	170	27	80	73	85	40,3	<b>RT1817</b>
1487	<b>51</b> (496)	150	<b>20</b> (198)	150	–	–	125	23	60	53	66	21,8	<b>RT2111</b>
4661	<b>126</b> (1237)	170	<b>51</b> (496)	170	<b>20,2</b> (198)	160	200	34	90	83	100	67,3	<b>RT2119</b>
2359	<b>81</b> (792)	150	<b>32</b> (309)	150	–	–	160	25	80	66	89	39,9	<b>RT3311</b>
8816	<b>202</b> (1985)	200	<b>81</b> (792)	200	<b>31,5</b> (309)	200	250	44	110	111	123	124,0	<b>RT3323</b>