

▼ ETR50H, Enerpac Trolley System (shown with Trolley Track Plates)



- **High transport speed:**
25 - 50 m/hour loaded,
100 m/hour unloaded
- **Suited for repetitive movements**
- **Runs on simple flat steel plate**
- **Ease of maintenance:**
– long maintenance intervals
– no consumables
- **Clean usage – electric driven**
- **Built-in synchronization – no need for forced external mechanical connection to synchronize movements**
- **Easy transport - compact design**
- **Hydraulic lifting cylinder option available**
- **Kits to accommodate other lifting options also available.**

▼ The trolley system speeds up offshore wind transition piece load out: the transition pieces are positioned in the clamping frames and moved along the track.



▼ ETR-Series electric trolley undergoing factory acceptance testing prior to shipment.



Safe & Synchronized Travel



Product Overview

The ETR-Series Trolley System is comprised of electrically-driven trolleys which can carry heavy loads along a fixed track system.

The entire system is controlled by a hand held wireless control system.

A typical system is comprised of 4 Trolleys, 2 Tracks and one Controller. Trolley Tracks and Wireless Control must be ordered separately.



Control Panel and Cables

Operate up to 8 trolleys (same capacity each) using control panel with included wireless controller:

- Automatic synchronization of traveling with an accuracy of 10 mm (0.39 inch)
- Dual-band radio with automatic frequency search
- Wireless remote operation
- High and low speed settings
- Emergency stop switch
- Control cables operate trolley and provide feedback to controller.

Control Panel

Model Number (380-415 VAC, 32A)	Dimensions (mm)			 (kg)
	L	W	H	
ETR-CPW8	1290	600	1100	250

Control Cables

Model Number	Description
ETR-CBL-15	15 metres control cable
ETR-CBL-25	25 metres control cable



ETR-Trolley System

The Enerpac Trolley System provides an alternative method with increased benefits over traditional skidding methods.

Load movements are more stable due to the continuous movement and ability to precisely control travel speed including acceleration and deceleration.

Key features:

Low speed (loaded):	25 m/hr
High speed (loaded):	50 m/hr
Travel speed unloaded:	100 m/hr
Accuracy:	10 mm
Sideload:	1,5% rated load
Sound Level:	< 80 dBA

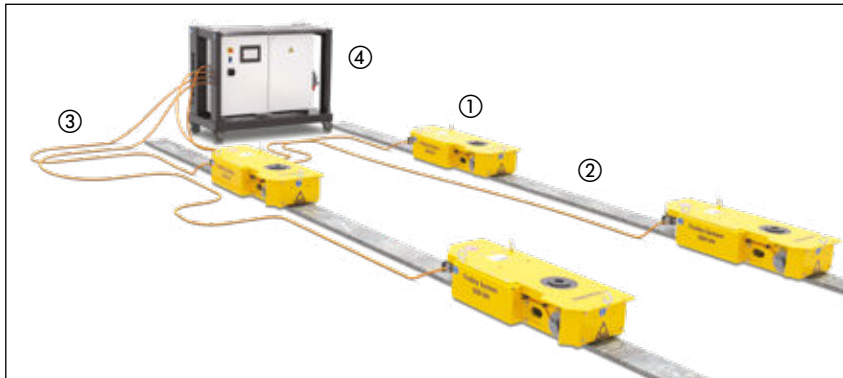

- ① Electric Trolley ETR-Series
- ② Track Plate ETR-TP-015 or ETR-TP-030
- ③ Control Cable ETR-CBL-15 or ETR-CBL-25
- ④ Control Panel ETR-CPW8 (including wireless remote)
- ⑤ Split-Flow Electric Pump - SFP-Series Not shown. Optional for units with hydraulic cylinders

ETR50

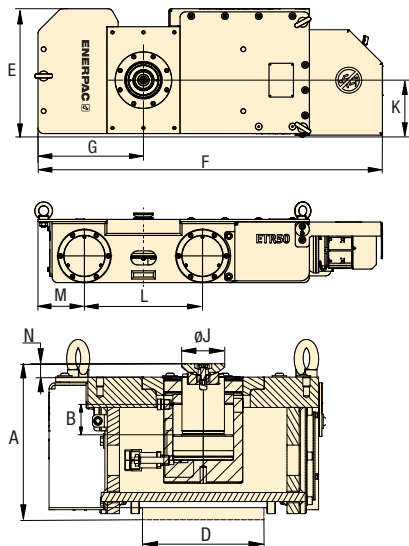

ETR100

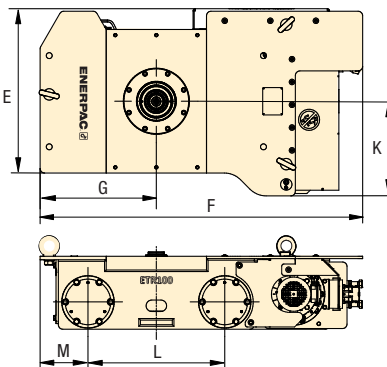

ETR Series



Capacity Per Trolley:

500 - 1000 kN

Travel Speed (loaded):

25 - 50 m/hr

Motor Power:

0,38 - 0,75 kW



Trolley Track Plates

Track plates provide level guidance and support for the trolley. Two plates placed side-by-side are used for operation of

ETR100-Series Trolleys. Maximum inclination of tracks is 0,2 degree.

Model Number	Description
ETR-TP-015	1,5 m Trolley track plate
ETR-TP-030	3,0 m Trolley track plate



Additional Mounting Options

Mounting kits are available to accommodate other lifting and rigging solutions.

Model Number	Description
ETR50-SMK	Enerpac SCJ50 on ETR50
ETR100-SMK	Enerpac SCJ100 on ETR100
ETR50-BMK	Swivel beam mount on ETR50
ETR100-BMK	Swivel beam mount on ETR100

Capacity per Trolley Unit ton (kN)	Model Number (one unit)	Motor Power (kW)	Dimensions (mm)											(kg)
			A	Hydraulic Stroke ¹⁾	Track Width ²⁾	E	F	G	J	K	L	M	N	
50 (500)	ETR50	0,38	245	–	200	456	1225	375	125	202	420	165	10	310
	ETR50H		257	50					71				22	
100 (1000)	ETR100	0,75	346	–	400	821	1415	510	170	415	600	210	15	850
	ETR100H		349	100					71				19	

¹⁾ ETR50H includes HCG502 Cylinder with CATS50 Swivel Saddle. ETR100H includes HCG1004 Cylinder with CATS101 Swivel Saddle.

²⁾ ETR100 series uses two track plates side-by-side.