

# 12" SCREWED HYDRALITE

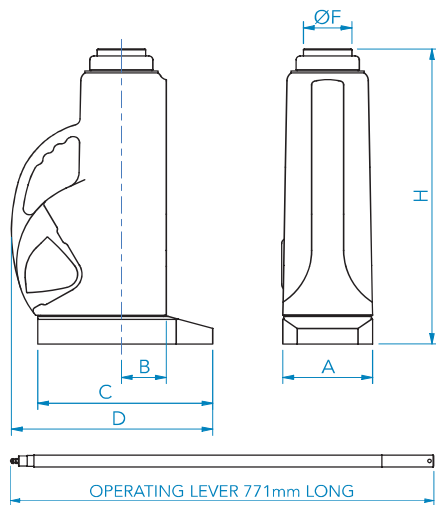

Product Code	PS1220S	PS1230S	PS1260S
Ram Capacity	20 Tonne	30 Tonne	60 Tonne
Oil Capacity	1.14 Litres	1.71 Litres	2.84 Litres
Stroke - mm (ins)	305 (12)	305 (12)	305 (12)
Lift per Stroke - mm (ins)	1.1 (0.042)	0.7 (0.026)	0.3 (0.013)
Weight	16.7 kg	23.4 kg	43.7 kg
Working Pressure	682 bar (9,900 PSI)	644 bar (9,350 PSI)	644 bar (9,350 PSI)
Maximum Effort on Lever	54 kg	52 kg	52 kg
Dimensions	mm (ins)	mm (ins)	mm (ins)
A - Width	121 (4.75)	140 (5.5)	190 (7.5)
B - Centre Ram to Face	60 (2.38)	70 (2.75)	92 (3.625)
C - Base Length	246 (9.69)	273 (10.75)	339 (13.375)
D - Overall Depth	289 (11.38)	311 (12.25)	384 (15.375)
F - Ram Diameter	60 (2.38)	76 (3)	108 (4.25)
H - Closed Height	438 (17.25)	451 (17.75)	500 (19.687)
<b>Service Kit Number</b>	<b>133930</b>	<b>133932</b>	<b>133935</b>

**TANGYE**