

▼ RLT-Series, Low-Height Telescopic Cylinder



- **Single-acting, load-return**
- **Nitrocarburized surface treatment inside and out provides corrosion protection**
- **For use in confined spaces: machinery positioning, tool fastening**
- **Mounting bolt holes for easy fixing**
- **Up to 3% side-load of maximum capacity**
- **Design safety factor complies with ASME B30.1 & EN1494**
- **CR400 coupler for compatibility with standard product**
- **High-Alloy steel for maximum strength.**

For longer cylinder strokes in confined spaces



RLT-Series, Low-Height Telescopic Cylinders

Enerpac compact, low-height telescopic cylinders are available with two or three pistons, and can lift loads up to 40 mm in a single movement.

Nitrocarburization surface treatment for improved wear resistance and corrosion protection for increased safety and longer service life in harsh conditions. The longer stroke length of telescopic cylinders will save you time and simplify projects by moving a load a greater distance and eliminating the use of temporary cribbing.



Multi-Stage Cylinders

1st Stage: maximum load capacity at lower stroke.

2nd Stage: extended stroke with lower capacity than the 1st stage.

Final Stage: maximum stroke extension with lowest capacity.



Cylinder Capacity at Maximum Stroke ton (kN)	Maximum Stroke (mm)	Model Number	Collapsed Height	Extended Height	Oil Capacity (cm ³)
			A (mm)	B (mm)	
4,4 (43)	17	RLT40	45,0	62,0	21
4,4 (43)	23	RLT41	54,0	77,0	51
11,4 (111)	18	RLT110	54,5	72,5	48
11,4 (111)	40	RLT111	89,0	129,0	241
23,7 (232)	27	RLT230	75,0	102,0	150
23,7 (232)	32	RLT231	96,0	128,0	303
31,5 (309)	29	RLT311	89,0	118,0	224
50,6 (496)	26	RLT501	96,0	122,0	283
74,1 (727)	26	RLT741	114,0	140,0	426

Low-Height Telescopic Cylinders, Single-Acting



Assisted-return Pumps with Venturi Valve Technology

To improve productivity and plunger retraction,

Enerpac offers valve configurations designed to accelerate your cylinder retraction speeds, ZU4 and ZE-Series pumps feature **Venturi Valve Technology** to facilitate the faster return of single-acting load and spring-return cylinders. See enerpac.com for details.

Page: 123



4-way Manifold assembly complete with gauges

Offering ease of portability and convenience with an ergonomic robust design,

ready for use. Enerpac's CR400 female couplers on all ports allow the manifold to be quickly connected to up to 4 cylinders. Glycerine filled, 700 bar gauges allow operators to work safely. All protected by the robust protection frame.

Manifold Type (Used for cylinders)	Model Number
4x Single-acting	AMGC41
4x Double-acting	AMGC42

RLT Series



Capacity:

4,4 - 74,1 ton

Stroke:

17 - 40 mm

Maximum Operating Pressure:

700 bar



WARNING:

If several telescopic cylinders need to be controlled simultaneously Enerpac recommend the use of EVO-Series Synchronous Lifting Pumps. Enerpac advise not to use SFP-Series Split-Flow pumps to operate several telescopic cylinders at a time due to the volume difference on the different stages.

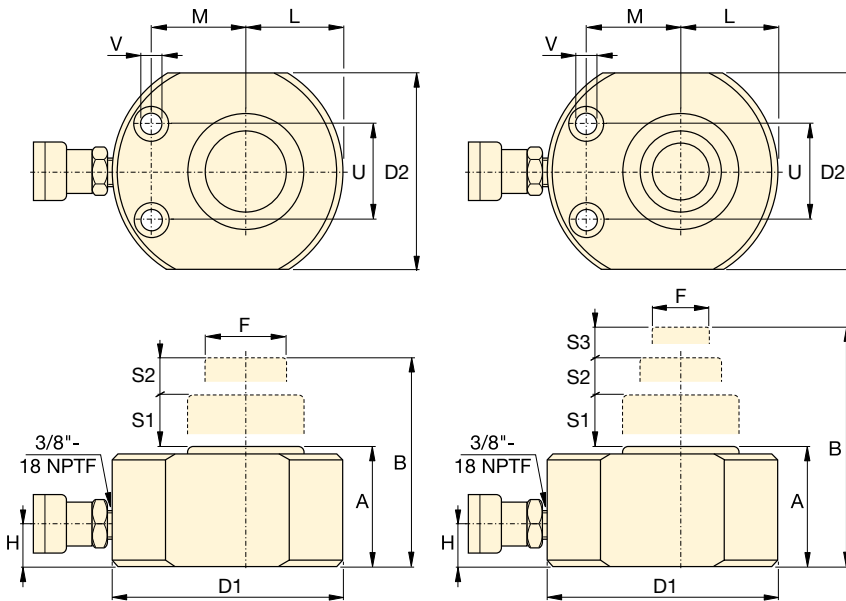

RLT-Cylinders

Mounting Hole Dimensions (mm)

Model Number	Bolt Distance	Hole Diameter	Counter Bore Diameter	Counter Bore Depth
	U	V		
RLT40	37	6,5	11	7
RLT41	50	9,0	14	9
RLT110	50	9,0	14	9
RLT111	76	13,0	20	13
RLT230	67	13,0	20	13
RLT231	76	6,5	11	7
RLT311	76	13,0	20	13
RLT501	76	6,5	11	7
RLT741	117	9,0	14	9

1st Stage		2nd Stage		3rd Stage		Outside Diameter D1 x D2 (mm)	Plunger Diameter F (mm)	Bottom to Advance Port H (mm)	Plunger to Base L (mm)	Plunger to Mounting Hole M (mm)	 (kg)	Model Number
Capacity ton (kN)	Stroke S1 (mm)	Capacity ton (kN)	Stroke S2 (mm)	Capacity ton (kN)	Stroke S3 (mm)							
11,4 (111)	11	4,4 (43)	6	-	-	83 x 56	25	20	29,0	33	1,8	RLT40
23,7 (232)	11	11,4 (111)	7	4,4 (43)	5	102 x 80	25	20	41,0	39	3,1	RLT41
23,7 (232)	11	11,4 (111)	7	-	-	102 x 80	38	20	41,0	39	3,0	RLT110
74,1 (727)	16	31,5 (309)	13	11,4 (111)	11	165 x 140	38	25	70,5	66	13,1	RLT111
50,6 (496)	16	23,7 (232)	11	-	-	140 x 114	57	20	58,0	56	7,6	RLT230
94,7 (929)	16	50,6 (496)	10	23,7 (232)	6	178 x 162	57	29	89,0	70	17,3	RLT231
74,1 (727)	16	31,5 (309)	13	-	-	165 x 140	60	25	70,5	66	13,0	RLT311
94,7 (929)	16	50,6 (496)	10	-	-	178 x 162	78	29	89,0	70	17,3	RLT501
143,5 (1407)	16	74,1 (727)	10	-	-	216 x 196	95	35	108,0	78	30,4	RLT741