

## EVERY JOINT IS DIFFERENT.

# EVOTORQUE® 2'S INTELLIGENT JOINT SENSING TECHNOLOGY ALWAYS DETECTS WHICH TYPE OF BOLT YOU ARE WORKING WITH.

Traditional electronic torque tools give vastly different results depending on the joint type. Norbar's intelligent joint sensing technology eliminates these issues so that you can be confident in your bolting work.

### Hard joints

(High Torque Rate\*)

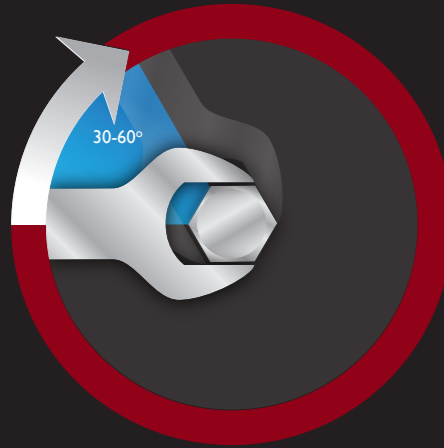

Joints completed within the range 30-60 degrees

### Soft joints

(Low Torque Rate\*)

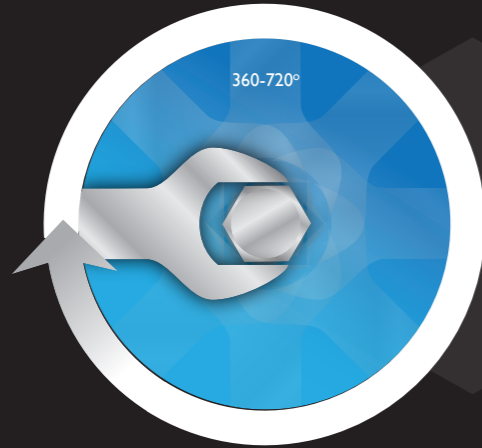

Joints completed within the range 360-720 degrees

\*High torque rate and low torque rate as defined by ISO5393 "Rotary tools for threaded fasteners- Performance test method"

## ACCURACY OF ELECTRONIC TORQUE TOOLS

### First generation

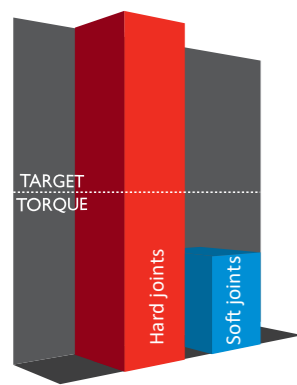

### Best of present generation

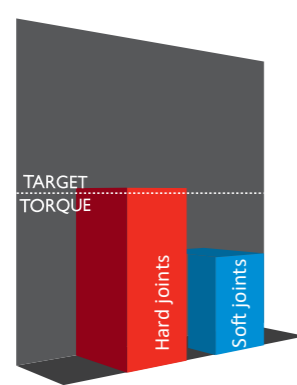

### New generation EvoTorque®2

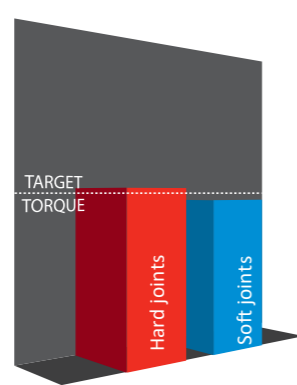

## GLOBAL SERVICE

Norbar is the only torque equipment manufacturer capable of offering tool and instrument calibration services to the original factory standard on four continents.

Accredited laboratories in Australia, USA, Singapore, China and India operate the same equipment and procedures as the UKAS accredited laboratory within our headquarters in the UK.



**NORBAR TORQUE TOOLS LTD**  
Wildmere Road, Banbury, Oxfordshire, OX16 3JU  
UNITED KINGDOM  
Tel + 44 (0)1295 753600  
Email sales@norbar.com



**NORBAR TORQUE TOOLS**  
45-47 Raglan Avenue, Edwardstown  
SA 5039  
AUSTRALIA  
Tel + 61 (0)8 8292 9777  
Email enquiry@norbar.com.au



**NORBAR TORQUE TOOLS INC**  
36400 Biltmore Place, Willoughby  
Ohio 44094  
USA  
Tel + 1 866 667 2272  
Email inquiry@norbar.us



**NORBAR TORQUE TOOLS PTE LTD**  
194 Pandan Loop, #07-20 Pantech Business Hub  
SINGAPORE 128383  
Tel + 65 6841 1371  
Email enquires@norbar.sg



**NORBAR TORQUE TOOLS (SHANGHAI) LTD**  
91 Building- 7F, No. 1122 North Qinzhou Road,  
Xuhui District, Shanghai  
CHINA 201103  
Tel + 86 21 6145 0368  
Email sales@norbar.com.cn



**NORBAR TORQUE TOOLS INDIA PVT. LTD**  
Plot No A – 168 Khairne Industrial Area  
Thane Belapur Road  
Mahape Navi Mumbai – 400 709  
INDIA  
Tel + 91 22 2778 8480  
Email enquiry@norbar.in

www.norbar.com



Part number 07570 | Issue 3

## NORBAR PRODUCT PORTFOLIO



Torque Screwdrivers



Torque Wrenches



Electronic Torque Wrenches



Manual Torque Multipliers



Pneumatic Torque Tools



Electronic Torque Tools



Torque Measurement Instruments



Torque Transducers



Ultrasonic Bolt Measurement



Calibration Services

## EVOTORQUE® 2

### AN EVOLUTION FOR TORQUE CONTROL



Distributed by

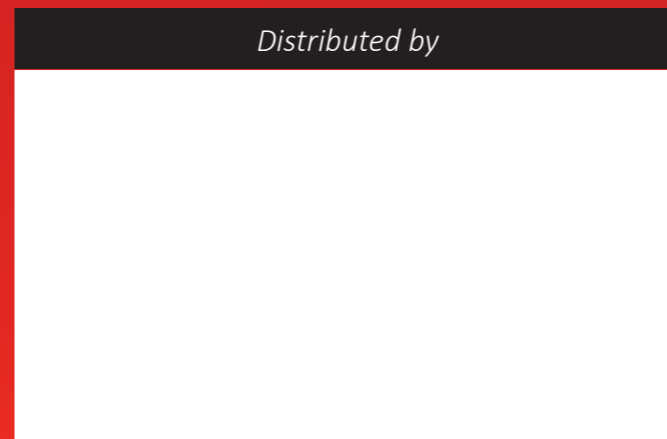



# NORBAR HAVE COMBINED PROVEN JOINT SENSING TECHNOLOGY, DATA MEMORY AND TRANSFER CAPABILITIES WITH TORQUE, TORQUE AND ANGLE AND AUDIT MODES TO PRODUCE A HIGHLY ACCURATE, USER FRIENDLY, ROBUST AND VERSATILE ELECTRONIC TORQUE TOOL

The EvoTorque®2 is an electronic torque tool designed for accurately applying torque to threaded fasteners. The unique 'intelligent joint sensing' technology continually measures the joint during tightening and, when necessary, employs dynamic braking to avoid torque over-shoot due to motor inertia.

Durable Peli case - for safer storage - available at an additional cost

Tool supplied in cardboard case as standard

Brushless motor for low maintenance

OLED display ensures visibility in all conditions

Key Lock feature prevents unauthorised usage

Clear indication of successful joint application

IP44 protection against dust and water ingress

Easily removable secondary handle for balanced handling of the tool

Tried and tested gearbox reliable and proven over more than a decade on the Pneumatic Torque Multiplier platform

Steel reactions supplied as standard. Bespoke reactions available, please see opposite page



## KEY FEATURES

- Multiple units of torque measurement, including N-m, lbf-ft, ft-lb and kgf-m
- Calibrated from 20% to 100% of tool range
- Torque, Torque & Angle and Torque Audit modes available
- In Torque and Angle Mode and Audit Mode, torque can be set from 10% of tool maximum
- Display and on-board storage of final torque or torque and angle values
- 3000 reading memory, time and date stamped
- Clear indication of successful joint application
- USB and Bluetooth® 4.0 data transfer (also called Bluetooth® Smart)
- Complimentary PC software 'EvoLog' for data management and tool configuration
- 12 user IDs can be downloaded to the tool and results can be stored against individual users
- 20 unique standalone targets plus 20 unique work group targets for each work group
- Results can be output in CSV (comma-separated values) format for users not able to use EvoLog

- Ability to produce and store real time graphs via EvoLog
- Torque & Angle with Final Torque
- 'Usage' counter gives the ability to see the amount of times the tool has been used since the last reset
- "Operation Direction" feature designed primarily for undoing bolts. When doing sequence tightening, it is now possible to undo an incorrectly tightened bolt without interrupting the sequence.
- Two stage tightening gives faster application of a Snug Torque & Angle Target
- "Turn Angle" option can be used to check if bolts have already been tightened in an assembly process
- Allows tool integration into third party control systems
- Two different lock levels, lock level 1 as per previous lock, lock level 2 will not allow user to exit the run screen or change the target
- Maximum Audit Mode target angle increased to 720 degrees

On-board control box making the tool more portable and convenient

## TECHNICAL SPECIFICATION

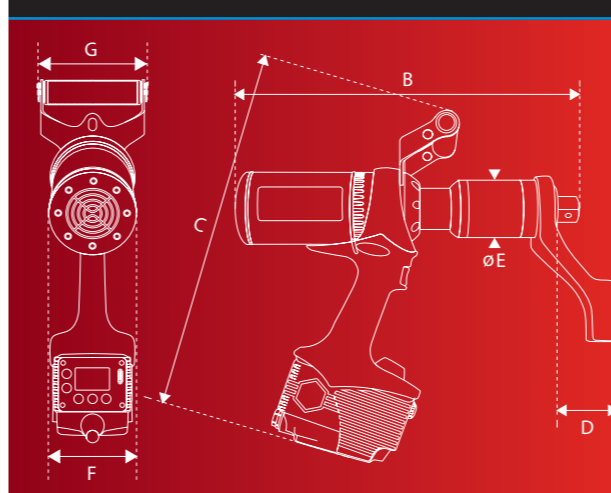

Please refer to the table on the right for EvoTorque®2 dimensions

MODEL	ET-72-1000-110 ET-72-1000-230	ET-72-1350-110 ET-72-1350-230	ET-72-2000-110 ET-72-2000-230	ET-80-2700-110 ET-80-2700-230	ET-92-3500-110 ET-92-3500-230	ET-92-4000-110 ET-92-4000-230	ET-119-6000-110 ET-119-6000-230	ET-119-7000-110 ET-119-7000-230
Part Number - 110V	180230.B06	180231.B06	180232.B08	180239.B08	180237.B08	180238.B08	180235.B12	180236.B12
Part Number - 230V	180220.B06	180221.B06	180222.B08	180229.B08	180227.B08	180228.B08	180225.B12	180226.B12
Square Drive	¾"	¾"	1"	1"	1"	1"	1 ½"	1 ½"
Range	N-m	200 - 1000	270 - 1350	400 - 2000	270 - 2700	700 - 3500	800 - 4000	1200 - 6000
	lbf-ft	148 - 738	199 - 996	295 - 1475	199 - 1991	515 - 2580	590 - 2950	885 - 4425
Speed rpm	21	17	11	10	6	6	3.3	3.3
Tool Weight	kg	10.4	10.4	10.8	10.75	12.85	12.85	16.8
	lb	22.9	22.9	23.8	23.7	28.4	28.4	37
Reaction Weight	kg	1.5	1.5	1.5	1.5	2.6	2.6	3.9
	lb	3.3	3.3	3.3	3.3	2.9	2.9	8.6
B (mm)	390	390	425	393	450	450	480	480
C (mm)	438	438	438	438	438	438	438	438
D (mm)	77	77	77	75	75	75	95	95
E (ø mm)	72	72	72	80	92	92	119	119
F (mm)	100	100	100	100	100	100	115	115
G (mm)	135.5	135.5	135.5	135.5	135.5	135.5	135.5	135.5



- Supplied with complimentary PC software "EvoLog" for data management and tool configuration
- Send 'Log Results' in real time
- Output results in CSV format for users not able to use EvoLog
- Ability to produce and store real time graphs

- Several reaction bar styles available, including restricted space applications
- Steel and aluminium versions available plus specific reactions for the Wind Industry