

HV 0516 Manual drive stacker with manual-hydraulic lift

Capacity 500 kg

Ideal for the occasional, internal application of stacking and transporting of palletised goods, loading and unloading of shelves and lorries.

Features

- Ergonomic safety control handle for one-hand operation of lifting, driving and lowering.
- Handlebars for easy operation.
- Lowering speed can be finely metered for sensitive lowering of the load.
- Single-acting hand pump with increased lift per handle stroke.
- Robust mast construction with hard chromium plated piston.
- Steering roller with brake for safe parking of the hand stacker.

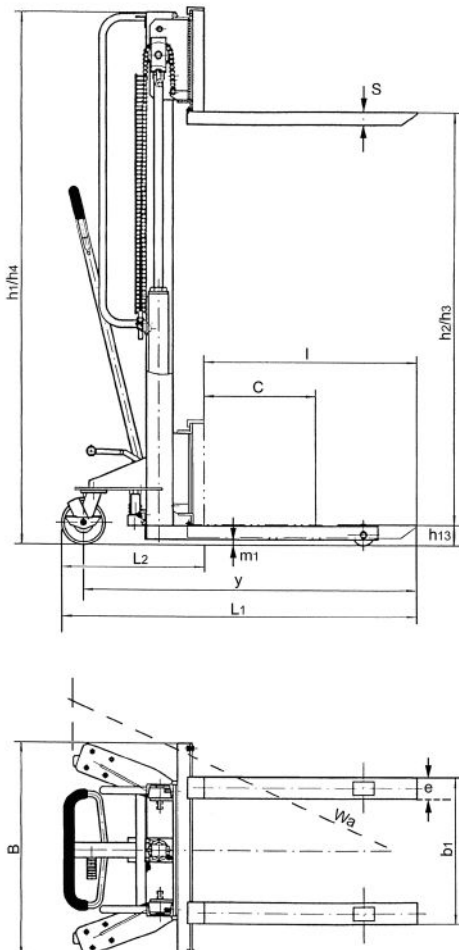

Technical data HV 0516

Model	HV 0516
Art.-No.	40005551
Capacity, kg	500
Load center c, mm	600
Wheelbase y, mm	1630
Weight, kg	160
Tyre type ¹	PA/PUR
Steering rollers, mm	145 x 40
Load rollers, mm	80 x 35
Number of wheels/load rollers	2/2
Height, mast retracted h1, mm	2000
Freelift h2, mm	1520
Stroke h3, mm	1520
Height, mast extended h4, mm	2000
Lifting height max. h3 + h13, mm	1600
Fork height lowered h13, mm	90
Overall length L1, mm	1750
Length incl. apron L2, mm	480
Overall width B, mm	830
Fork height s, mm	50
Fork width e, mm	120
Fork length l, mm	1150
Outside dimension of forks adjustable up to b1, mm	270/810
Ground clearance m1, mm	25
Turning circle radius Wa, mm	1500
Lift per one crank rotation with/without load, mm	20/45

¹PA... Polyamide, PUR... Polyurethane