

Item	Stumec CH65 Slewing Jack
Drawing Set	WRPD 010
Issue Date	January 2013
Page	1 of 2
Issue No	1

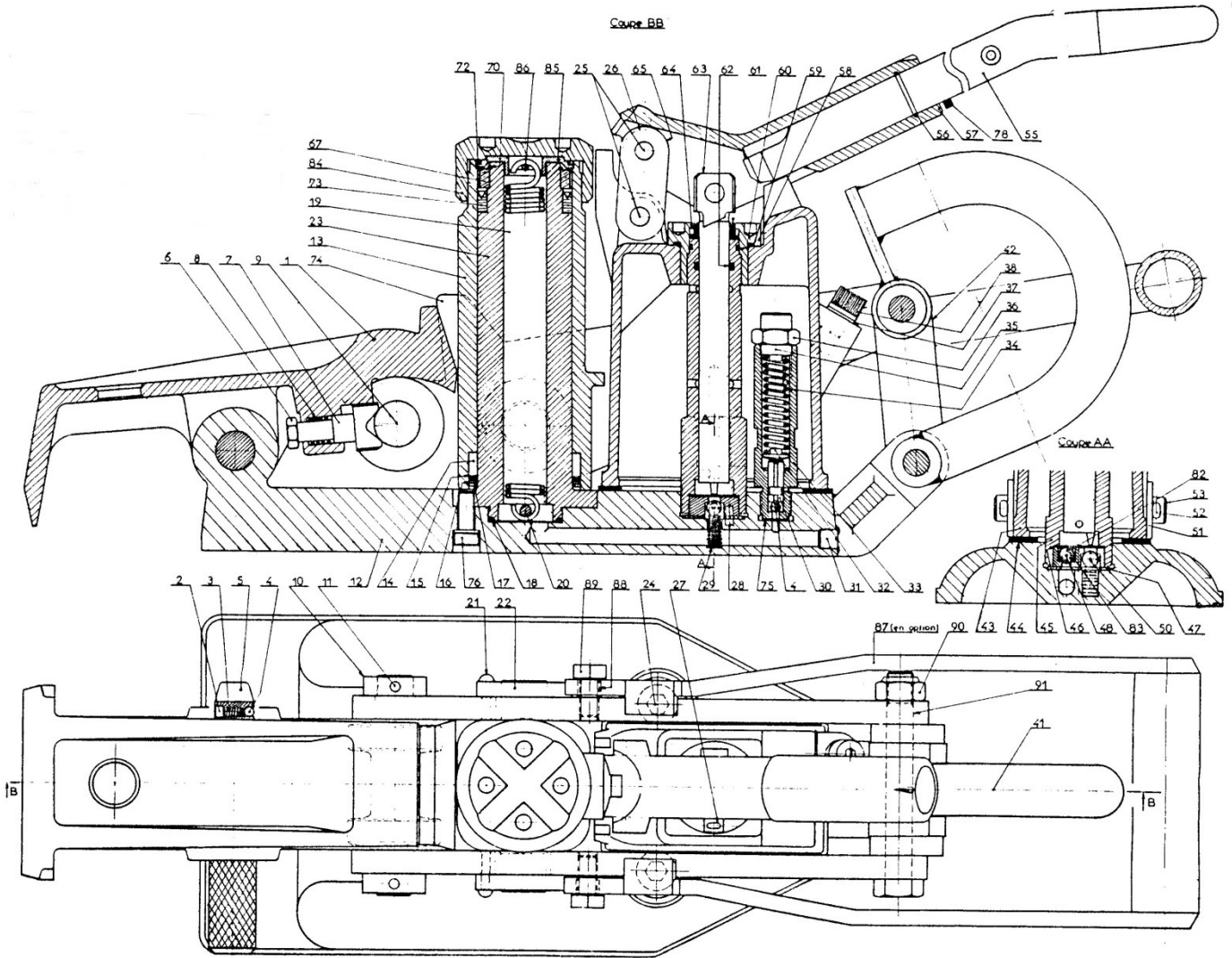

Item	Qty	Description	Item	Qty	Description
1	1	Slewing shoe	42	2	Rod
2	1	Spindle spring bearing part	43	1	Oil reservoir
3	1	Spindle spring	44	1	Oil reservoir seal
4	2	Ball 6mm	45	1	Pump lining (See 63)
5	1	Spindle	46	1	Washer
6	1	Nut Hm8	47	1	Valve seal
7	1	Lock pin	48	1	Ball
8	1	Lock pin spring	50	1	Ball
9	1	Roller	51	2	Washer
10	2	Roller lock ring	52	2	Pin
11	2	Pin V 5 x 50	53	1	Ball axle
12	1	Base	55	1	Lever rod
13	1	Cylinder	56	1	Flexible retaining ring
14	1	Cylinder guide ring	57	1	Actuation lever
15	1	Lifting piston wiper seal	58	1	Assembling nut
16	1	Lock Ring	59	1	O ring
17	1	Lock Ring	60	1	O ring
18	1	O ring	61	1	Pump piston wiper
19	1	Cylinder drawback spring	62	1	O ring
20	1	Spring lock pin	63	1	Pump piston 45 & 63
21	2	Rivet	64	1	Compensation washer
22	2	Trunnion ring	65	1	Rod
23	1	Lifting piston	67	1	Guide ring
24	2	Screw	70	1	Flexible ring
25	3	Pump and rod axle	72	1	O ring
26	2	Lever keying washer	73	1	Lip seal
27	3	Pin	74	2	Tipper
28	1	Lug	75	1	Copper gasket
29	1	Delivery ball spring	76	6	Screw
30	1	By pass ball thrust	78	1	Flexible pin
31	2	Plug	82	1	Ball stop
32	1	By pass spring guide	83	1	Valve housing
33	1	By pass chamber	84	1	Cylinder plug
34	1	By pass	85	1	Spring washer
35	1	By pass adjusting screw	86	1	Axle
36	1	Nut	87	1	Carrying handle
37	1	Washer	88	2	Spacer
38	1	Screw	89	2	Screw
40	2	Tilt washer	90	1	Locknut
41	1	Handle	91	1	Screw
			92	1	Overload relief Valve